



P.O. Box 490, Schumacher, ON P0N 1G0  
 Phone: 866.754.9334  
 Fax: 705.264.4401

# BOOTH ACCESSORIES RENTAL

THE BIG EVENT Mining & Exploration Expo  
 Timmins, MAY 19-20, 2010

Company: \_\_\_\_\_ Booth#:   
 Street: \_\_\_\_\_ City: \_\_\_\_\_  
 Prov: \_\_\_\_\_ Postal Code: \_\_\_\_\_  
 Phone#: \_\_\_\_\_ Fax#: \_\_\_\_\_  
 Contact Person: \_\_\_\_\_

Card Holder Name: \_\_\_\_\_  
 Credit Card Number: \_\_\_\_\_  
 Signature \_\_\_\_\_  
 Expiry Date \_\_\_\_\_ / \_\_\_\_\_  
 Visa  MasterCard  Cheque  NO AMEX

**25% ADMINISTRATION CHARGE WILL APPLY TO ORDERS CANCELLED 2 WEEKS PRIOR TO SHOW.  
 NO ORDER WILL BE PROCESSED UNTIL PAYMENT IS RECEIVED. ORDERS MUST BE PRE-PAID IN FULL  
 BEFORE CLOSING AT 5 PM MONDAY PRIOR TO SHOW DATE TO RECEIVE PRE-SHOW PRICE.**

#	DESCRIPTION	PRE-SHOW	ON SITE	QTY	TOTAL
1	PADDED ARM CHAIR	\$12.00	\$15.00		
2	DIRECTOR'S CHAIR, 30" HIGH	15.00	18.75		
3	BLACK/WOOD BAR STOOL WITH BACK	15.00	18.75		
4	FOLDING CHAIR	4.00	5.00		
5	CARPET: RED BLUE GREY GREEN 10' x 10' 10' x 20'  3/8" FOAM UNDERPAD (PRICE PER SQ. FT.)	63.00 126.00  0.50	78.75 151.50  0.75		
6	UNDRAPED TABLES: 30" W. BY 8' 6' 4' UNDRAPED TABLES: 18" W. BY 8' 6' 4'	16.75 16.75	21.00 21.00		
7	COFFEE TABLE (34" RND.) 18" HIGH 30" HIGH 42" HIGH	25.00	31.50		
8	SKIRTED TABLES (INCL. TABLE, PLASTIC COVER, FRONT & 2 SHORT SIDES SKIRTED) 8' 6' 4' 30" WIDE OR 18" WIDE ROYAL BLUE GOLD RED TEAL NAVY BLUE WHITE BLACK BURGANDY *** TO SKIRT 4 SIDES OR CHANGE TABLE SIZE	40.00  15.75	50.00  16.50		
9	LEG EXTENDERS (ELEVATES TABLE HEIGHT TO 42") BLUE WHITE OR BLACK SKIRTING ONLY	12.60	15.75		
10	2-BULB FLOODLIGHT	42.00	50.50		
11	3-BULB FLOODLIGHT	52.50	63.00		
12	EASEL	16.75	21.00		
13	SIGN STAND 22" x 28"	15.75	19.50		
14	COAT TREE	8.40	10.50		
15	COAT RACK C/W HANGERS	12.60	15.75		
16	WASTE BASKETS	6.30	7.85		
17	ARTIFICIAL PLANTS (4' TO 6') OR 2' LIVE PLANT	21.00	26.25		
18	A DEDICATED 15 AMP ELECTRICAL LINE	75.00	100.00		
19	FORK LIFT MOVE IN AND MOVE OUT	100.00	125.00		
Drapery	ROYAL BLUE GOLD RED TEAL GREEN NAVY BLUE WHITE BLACK BURGANDY 8' HIGH DRAPE BACK PRICE PER LINEAR FOOT 3' HIGH DRAPE SIDES PRICE PER LINEAR FOOT	5.50 3.40	6.80 4.20		

AUTHORIZING SIGNATURE:  
 X \_\_\_\_\_

SUBTOTAL: \_\_\_\_\_  
 5% GST: \_\_\_\_\_  
 8% PST: \_\_\_\_\_  
 GRAND TOTAL: \_\_\_\_\_

ALL RATES ABOVE ARE FOR DURATION OF SHOW. ALL CLAIMS/DISCREPANCIES MUST BE SETTLED PRIOR TO SHOW CLOSING.  
 REFUNDS WILL NOT BE GIVEN ON ANY ORDERS CHANGED OR CANCELLED ON-SITE.  
 ALL MATERIALS REMAIN THE PROPERTY OF HAHN RENTALS & WILL BE REMOVED UPON SHOW CLOSING.

# HAHN RENTALS

P.O. Box 490, Schumacher, ON P0N 1G0  
 Phone: 866.754.9334  
 Fax: 705.264.4401

## BOOTH ACCESSORIES RENTAL

THE BIG EVENT Mining & Exploration Expo  
 Timmins, MAY 19-20, 2010

Company: \_\_\_\_\_ Booth#:

Street: \_\_\_\_\_ City: \_\_\_\_\_

Prov: \_\_\_\_\_ Postal Code: \_\_\_\_\_

Phone#: \_\_\_\_\_ Fax#: \_\_\_\_\_

Contact Person: \_\_\_\_\_

Card Holder Name: \_\_\_\_\_

Credit Card Number: \_\_\_\_\_

Signature \_\_\_\_\_

Expiry Date \_\_\_\_\_ / \_\_\_\_\_

Visa  
  MasterCard  
  Cheque  
  NO AMEX

### POLE/PANEL SERIES

3' x 4' Panels  
 16" x 4' Header Panels  
 Silver, Charcoal, Royal Blue, Red, or Black

**\*CUSTOM DESIGN OF ANY OF THESE\*  
 EXHIBITS CAN BE ARRANGED.**

With these modular components, you  
 can order the following complete  
 displays:

Poles (up to 8') Prices available upon request  
 Panels (any size up to 3' x 4') Prices available upon request

J - HP Portable Exhibit Systems  
 10' Exhibit c/w 3 stem lights \$480.00  
 20' Exhibit c/w 6 stem lights \$970.00

K - VP Portable Exhibit Systems  
 10' Exhibit c/w 4 stem lights \$480.00  
 20' Exhibit c/w 8 stem lights \$970.00

L - Basic Exhibit System (Lights extra) \$330.00  
 M - Deluxe 20' Exhibit \$1080.00

8 - 75w stem lights, and  
 2 - 4' Trapezoidal Counters

N - 10' Hexxa Black Pop-up Display \$475.00

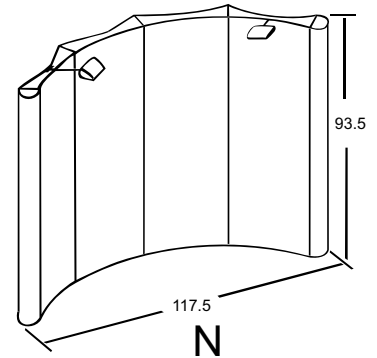
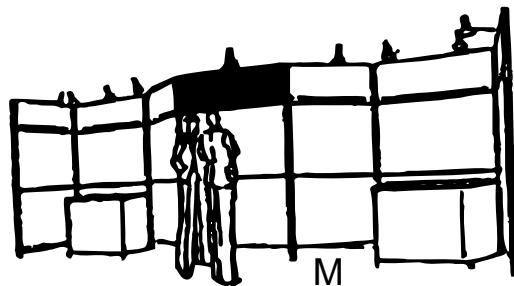
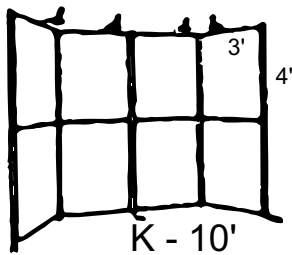
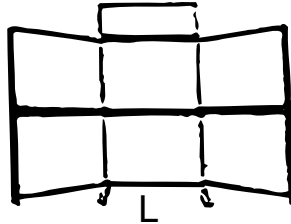
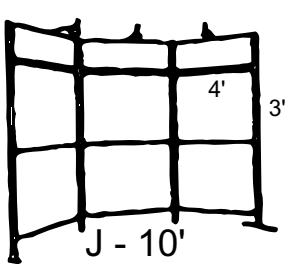

AUTHORIZING SIGNATURE:  
 X \_\_\_\_\_

ALL RATES ABOVE ARE FOR DURATION OF SHOW. ALL CLAIMS/DISCREPANCIES MUST BE  
 SETTLED PRIOR TO SHOW CLOSING.  
 REFUNDS WILL NOT BE GIVEN ON ANY ORDERS CHANGED OR CANCELLED ON-SITE.  
 ALL MATERIALS REMAIN THE PROPERTY OF HAHN RENTALS & WILL BE REMOVED UPON  
 SHOW CLOSING.

SUBTOTAL: \_\_\_\_\_

5% GST: \_\_\_\_\_

8% PST: \_\_\_\_\_

GRAND TOTAL: \_\_\_\_\_

G.S.T. R104250493

# HAHN RENTALS

P.O. Box 490, Schumacher, ON P0N 1G0  
 Phone: 866.754.9334  
 Fax: 705.264.4401

## BOOTH ACCESSORIES RENTAL

THE BIG EVENT Mining & Exploration Expo  
 Timmins, MAY 19-20, 2010

Company: \_\_\_\_\_ Booth#:

Street: \_\_\_\_\_ City: \_\_\_\_\_

Prov: \_\_\_\_\_ Postal Code: \_\_\_\_\_

Phone#: \_\_\_\_\_ Fax#: \_\_\_\_\_

Contact Person: \_\_\_\_\_

Card Holder Name: \_\_\_\_\_

Credit Card Number: \_\_\_\_\_

Signature \_\_\_\_\_

Expiry Date \_\_\_\_\_ / \_\_\_\_\_

Visa 
  MasterCard 
  Cheque 
  NO AMEX

25% ADMINISTRATION CHARGE WILL APPLY TO ORDERS CANCELLED 2 WEEKS PRIOR TO SHOW.  
 NO ORDER WILL BE PROCESSED UNTIL PAYMENT IS RECEIVED. ORDERS MUST BE PRE-PAID IN FULL  
 BEFORE CLOSING AT 5 PM MONDAY PRIOR TO SHOW DATE TO RECEIVE PRE-SHOW PRICE.

AUDIO/VIDEO  
 EQUIPMENT  
 RENTAL



DESCRIPTION	1 Day Use	Extra Days (1/2 price x # of days)	Total
T.V. / VHS or DVD COMBO			
14" Monitor c/w 1/2" VHS Player	70.00		
20" Monitor c/w 1/2" VHS Player	80.00		
20" Monitor c/w DVD Player	92.50		
VCRs			
1/2" VHS Player	40.00		
DVD Player	40.00		
Televisions			
20" Television	50.00		
27" Television	70.00		
Video Cart	20.00		
COMPUTER EQUIPMENT			
17" Flatscreen LCD Computer Monitor	75.00		
19" Flatscreen LCD Computer Monitor	125.00		
27" Flatscreen LCD Computer Monitor	150.00		
35 mm Slide Projector OR 60" Video Screen	35.00		
MISC. ITEMS			
Microwave Oven	45.00		
Bar Fridge	45.00		

AUTHORIZING SIGNATURE: \_\_\_\_\_  
 X \_\_\_\_\_

SUBTOTAL: \_\_\_\_\_

5% GST: \_\_\_\_\_

8% PST: \_\_\_\_\_

GRAND TOTAL: \_\_\_\_\_

All Rates Above Are For Duration Of Show. All Claims/Discrepancies Must be Settled Prior To Show Closing  
 REFUNDS will not be given on any orders changed or cancelled on site.  
 All materials remain the property of Hahn Rentals & will be removed upon Show closing.

P.O. Box 490, Schumacher, ON P0N 1G0  
 Phone: 866.754.9334  
 Fax: 705.264.4401

THE BIG EVENT Mining & Exploration Expo  
 Timmins, MAY 19-20, 2010

**Company:** \_\_\_\_\_ **Booth#:**

**Street:** \_\_\_\_\_ **City:** \_\_\_\_\_

**Prov:** \_\_\_\_\_ **Postal Code:** \_\_\_\_\_

**Phone#:** \_\_\_\_\_ **Fax#:** \_\_\_\_\_

**Contact Person:** \_\_\_\_\_

Card Holder Name: \_\_\_\_\_

Credit Card Number: \_\_\_\_\_

Signature \_\_\_\_\_

Expiry Date \_\_\_\_\_ / \_\_\_\_\_

Visa  
  MasterCard  
  Cheque  
  NO AMEX

25% ADMINISTRATION CHARGE WILL APPLY TO ORDERS CANCELLED 2 WEEKS PRIOR TO SHOW.  
 NO ORDER WILL BE PROCESSED UNTIL PAYMENT IS RECEIVED. ORDERS MUST BE PRE-PAID IN FULL  
 BEFORE CLOSING AT 5 PM MONDAY PRIOR TO SHOW DATE TO RECEIVE PRE-SHOW PRICE.

EXHIBIT  
 SYSTEMS  
 RENTAL

### FS 28 SERIES

FS 28/35" Folding Stackable 3 panel Display c/w 3 lights  
 FS 28/12" Header  
 Royal Blue, Silver, Charcoal Reversible

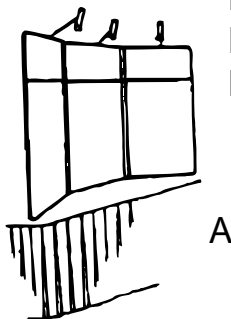
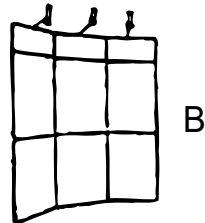
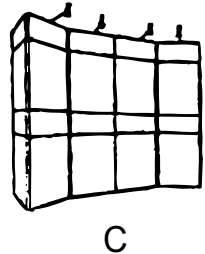
A - \$155.00  
 B - \$190.00  
 C - \$357.00

### FS 28 SERIES

FS 28/35" Folding Stackable 4 panel Display c/w 4 lights  
 FS 28/17" Header  
 Royal Blue, Silver or Charcoal Reversible

E - \$235.00  
 F - \$500.00

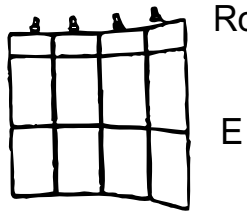
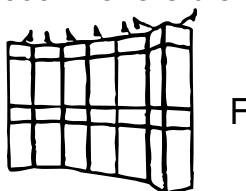
### FS PEDESTAL BASES AND TOPS

G - 12"h - \$49.00  
 24"h - \$55.00  
 35"h - \$60.00  
 H - 12"h - \$49.00  
 24"h - \$55.00  
 35"h - \$60.00  
 I - 35"H - \$68.00

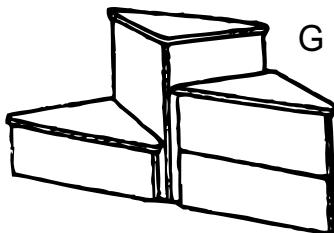
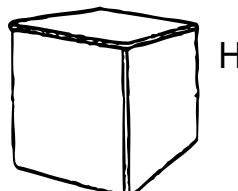
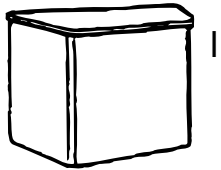
32.5" Triangular Counter Top - Silver  
 (FS 28 Series Bases)  
 26" Square Counter Top - Silver  
 (FS 22 Series Bases)  
 48" x 20" Trapezoidal Counter Top - Silver  
 Bases are Royal Blue, Silver or Charcoal

SUBTOTAL: \_\_\_\_\_

6% GST: \_\_\_\_\_

8% PST: \_\_\_\_\_

TOTAL: \_\_\_\_\_

REFUNDS WILL NOT BE GIVEN ON ANY CHANGED OR CANCELLED ORDERS ON-SITE.